

## NMOS: Si-NMOS Linear Arrays (PDA) and Carl Zeiss MMS / MCS Spectral Sensors

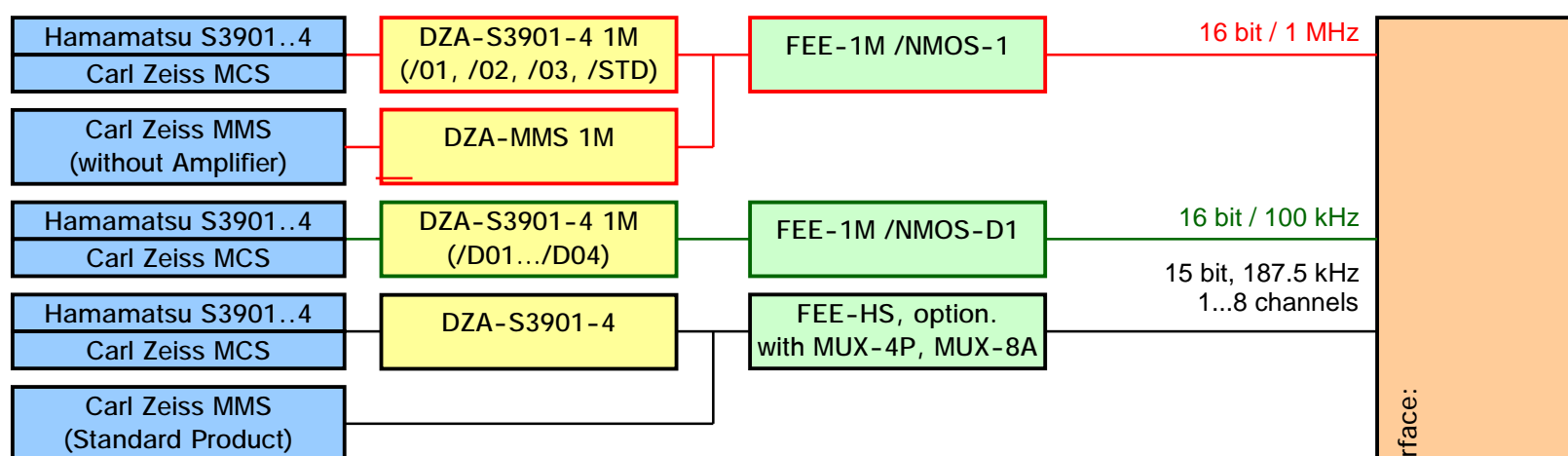

## CCD: Si-FFT CCD Arrays and Carl Zeiss MCS-CCD Spectral Sensors

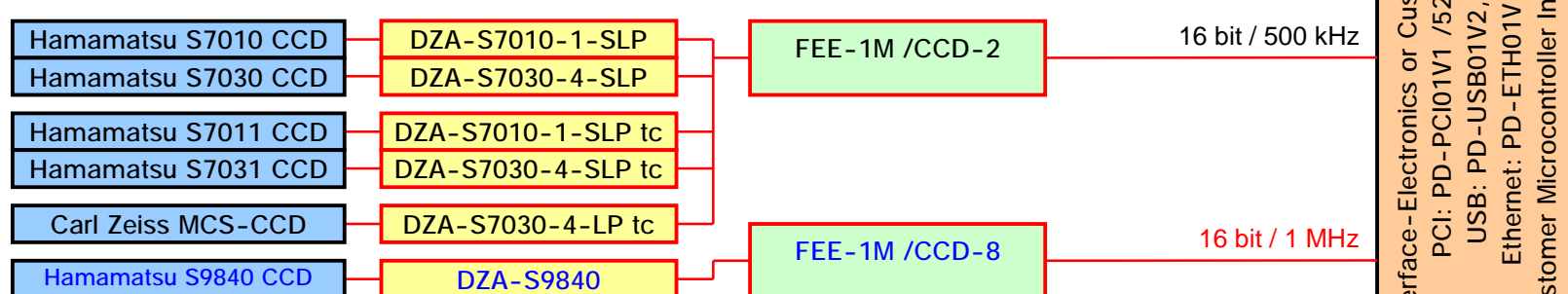

## InGaAs: InGaAs Multiplexed Arrays and Carl Zeiss PGS-NIR Spectral Sensors

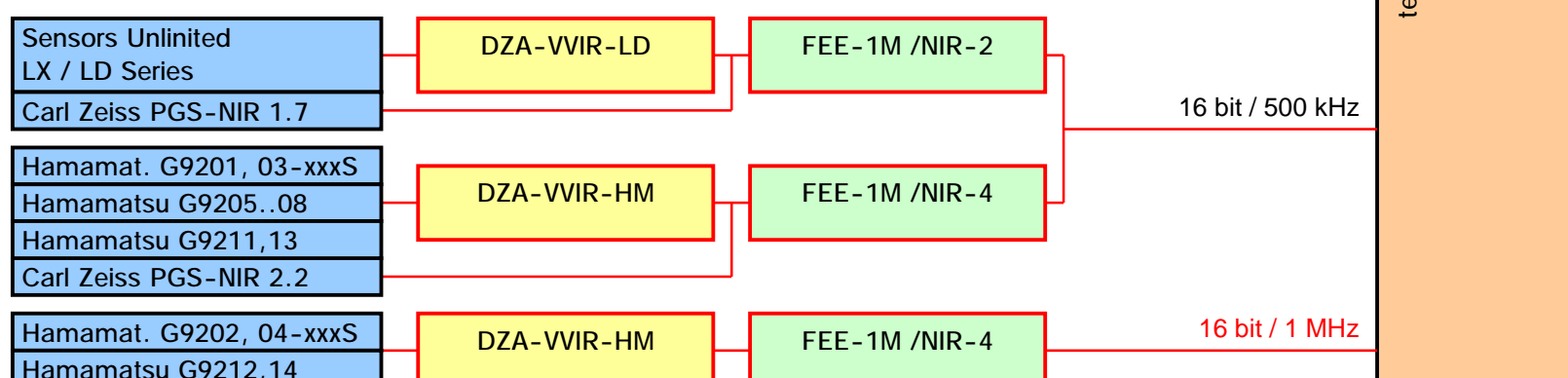

tec5 PC-Interface-Electronics or Customer Interface:  
 PCI: PD-PCI01V1 /52,  
 USB: PD-USB01V2,  
 Ethernet: PD-ETH01V1,  
 Customer Microcontroller Interface

**Red:** 16 bit / 500 kHz ... >= 1 MHz Pixelrate / Configuration based on Front End Electronics Type FEE-1M  
**Green:** 16 bit / 100 kHz Pixelrate / Configuration based on Front End Electronics Type FEE-1M  
**Black:** 15 bit / 187.5 kHz Pixelrate / Configuration based on Front End Electronics Type FEE-HS