

Preamplifier Electronics for Hamamatsu InGaAs Photodiode Arrays G9205...G9208 / G9211...G9214



DZA-VVIR-HM

Product ID: 0106252.22
Document: ds_dza-vvir-hm_102e.doc

In der Au 27
61440 Oberursel / Germany

Phone: +49 (0) 6171 / 9758 – 0
Fax: +49 (0) 6171 / 9758 – 50
E-Mail: sales@tec5.com
Internet: www.tec5.com

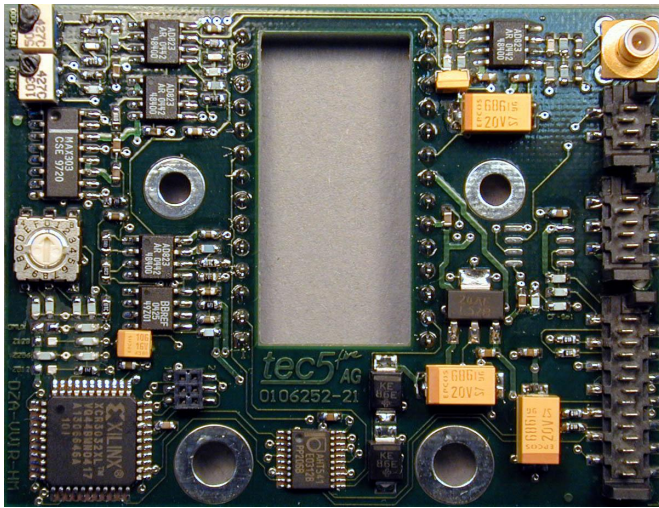

Short Description

- § Compact preamplifier electronics for Hamamatsu InGaAs photodiode arrays of series G9205 to G9214
- § Direct positioning of PCB on sensor chip
- § Device input: sensor chip
- § Device output: Front End Electronics with sensor interface ,Sensor_U1' (FEE-1M /NIR-x, FEE-NIR)
- § PCB dimensions: 72 mm x 55 mm
- § Connector for temperature controller

General

The preamplifier electronics DZA-VVIR-HM serves as an interfacing component between the Hamamatsu InGaAs photodiode arrays of series G9205 to G9214 and the Front End Electronics board of a tec5 operating electronics. Typically, the photodiode array is plugged into the connector DIL-28 on the soldering side of the PCB.

The interface to the Front End Electronics complies to the tec5 specification ,Sensor_U1' (MICS-14, MICS-4 and SMB socket with pin contact, video signal ,differential').

A Peltier cooler control electronics can access the preamplifier via a MICS-6 connector.

Features

The preamplifier board generates - based on the CLK and START signals - all signals necessary to read out a sensor chip. The analog signals from the sensor array are primed and are provided differentially for further processing (Video signal). The sampling point of time is indicated by the rising slope of the TRIGGER signal.

The pixel frequency of a 256 element array equals 1/8 of the CLK frequency – the frequency of a 512 array 1/4. The readout time is derived from the numbers of pixels N as:

$$t_{\text{readout}} = ((N \times p) + 8) / f_{\text{CLK}}$$

with $p = 8$ (256 pixels) or 4 (512 pixels). The preamplifier board switches automatically between ,odd' and ,even' pixels. After the output of all pixel signals an EndOfScan pulse is generated by the board. With this EOS signal, the integration period starts simultaneously for all pixels and ends with the next START pulse. The complete measurement cycle duration is equal to the integration time plus the readout time.

Technical Data

Diode array:	Hamamatsu InGaAs Linear Image Sensors, Type G9205 to G9208, G9211 to G9214 or compatibles
Number of pixels:	256 or 512
CLK frequency:	max. 4 MHz
Readout time:	0.514 ms at 4 MHz CLK
Min. integration time:	0.1 ms

Analog Range:

Output signal:	$\pm 0 \dots 3 \text{ V}$
Total gain:	1.4

Digital Input Control Signals (AHC level):

START:	Start of readout cycle, if signal 'START' is High and 'CLK' has a falling slope.
CLK:	Clock signal for the array. The pixel frequency is 1/4 (512 elements) and 1/8 (256 elements) of the CLK frequency

Digital Output Control Signals (AHC level):

TRIGGER	Signal for reading out the video signal, read with the rising slope
/EOS:	EndOfScan, Signal /EOS is High during readout procedure. After the final pixel is read, a Low pulse is generated for the time the CLK signal is high. This indicates the end of the array.

Signal Behavior:

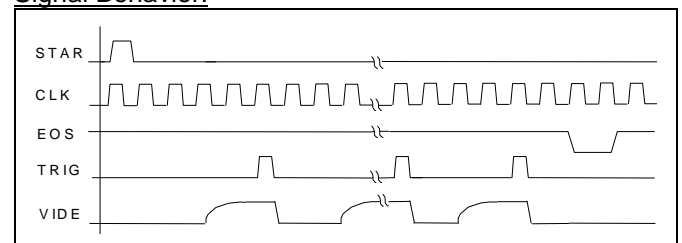

For further information see Hamamatsu datasheet.

Current consumption:
 +5V: typically < 35 mA
 -5V: typically < 25 mA

Ambient Conditions (DZA-VVIR-HM only):
 Operating temperature range: 0 °C ... 65 °C
 Storage temperature range: -40 °C...+70 °C
 Humidity (@25°C, non condensing): 10 % ... 90 %

Board Layout

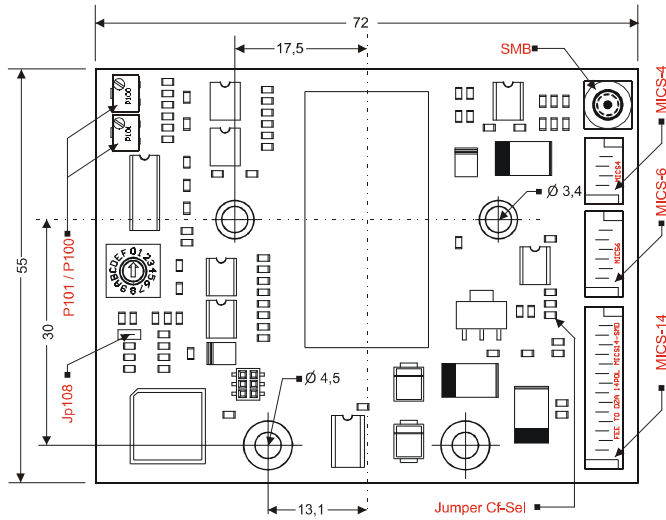

PCB DZA-VVIR-HM, component side

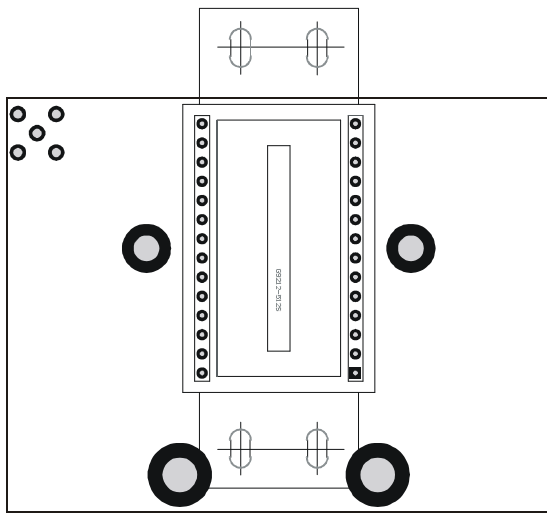

PCB DZA-VVIR-HM, soldering / sensor side

Mechanical Interfacing

Board dimensions: 72 mm x 55 mm
 Connector diode array: 2x sockets on soldering side of board
 Mounting of board: 2x holes, symmetric to diode array and 2x holes asymmetric

Electronic Interfaces

Type: tec5 specification ,Sensor_U1"
 Video output: SMB socket connector / alternatively MICS-4
 Digital control: MICS-14
 Cooling control: MICS-6

Pin Assignment MICS-14 Connector:

Pin	Designation	Pin	Designation
1	TRIGGER – Sync Video Grabber	2	START – Start of Scan
3	DIN1 (not used)	4	CLK - Sensor Clock
5	DIN2 (not used)	6	/EOS - End of Scan
7	0V - Digital Ground	8	-5V – Supply
9	0V - Digital Ground	10	+5V – Supply
11	DOUT1 (not used)	12	DOUT2 (not used)
13	I2C-SDA	14	I2C-SCL

Pin Assignment MICS-4 Conn.: MICS-6 Connector:

Pin	Designation	Pin	Designation
1	0V – Analog Ground	1, 2	Peltier +
4	0V – Analog Ground	3, 4	Peltier -
2	Video Out (inverted)	5	Thermistor
3	Video Out (non inverted)	6	Thermistor



Solder Jumpers / Potentiometer

Jumper JP108: open for 256 pixels
 closed for 512 pixels
 Jumper Cf-Sel: closed for ,gain = 1'
 Default settings: 256 pixels, gain = 1
 Potentiometer 100: Gain balance* (512 pixels)
 Potentiometer 101: Offset balance* (512 pixels)
 *: Even/Odd balance for 512 element array.

System Data

System data, realized with tec5 16 bit Operating Electronics incl. FEE-NIR and sensor G9208-256W (cooled, sensor temperature = -10 °C)
 Integration time: 1 ms
 Clock frequency: 312.5 kHz
 Intensity resolution: 16 Bit
 Ambient temperature: +25 °C
 Single pixel dark current noise: < 2 Counts rms

User Information

General

The information in this data sheet has been checked carefully. However, no responsibility is assumed for inaccuracies. tec5 reserves the right to make changes to any portion of this document without notice. Each product is tested carefully before being shipped. If, however, problems should occur while initial operation or during later operation, please first check your specific settings and correct installation (connectors).

Warranty

The warranty period for this product is 12 months. The warranty begins on the day of delivery. Within the warranty period, tec5 will repair free of charge any faulty functioning of the product resulting from faulty design or defective material. All other claims are excluded, in particular consequential damage.

Handling

The electronics is partly constructed in CMOS technology and is thus sensitive against electrostatic discharge. Take appropriate precautions whenever handling the component. Please switch off the power before connecting or disconnecting the product.