

MCS CCD Multi Channel- Spectrometer

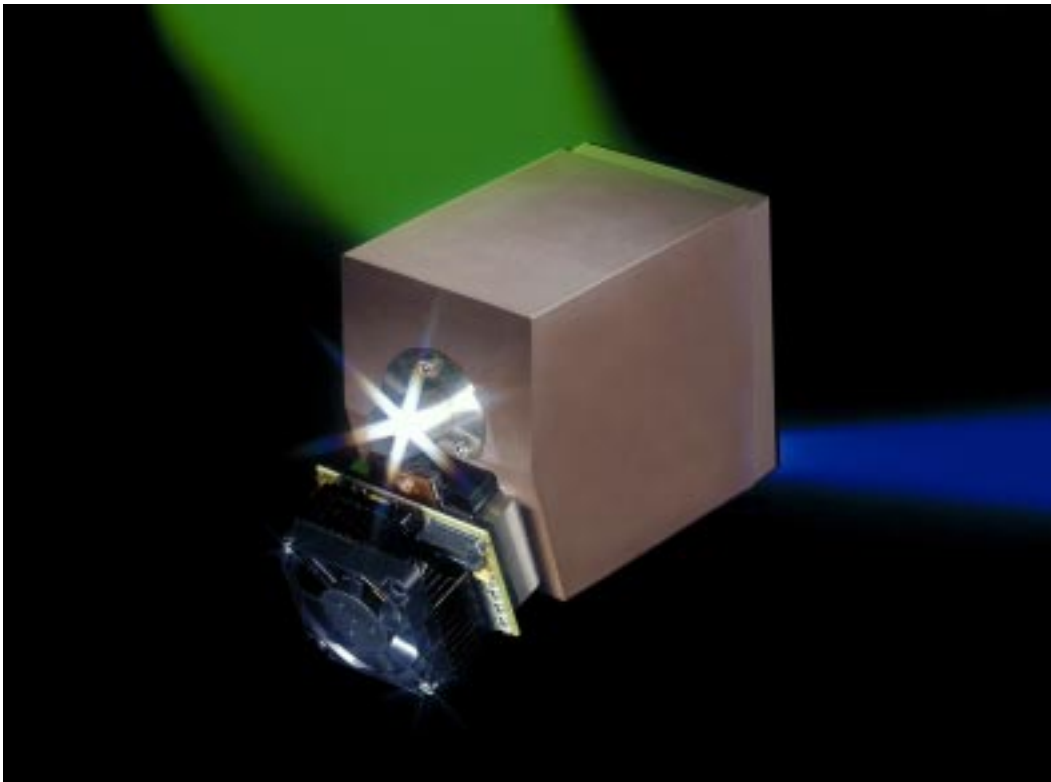

Product Information



Construction

The module consists of a spectrometer body made of patented ceramic structure with an aberration corrected concave grating, a fiber cross section converter or a mechanical slit as optical entrance and a thermoelectrically cooled CCD detector of Hamamatsu. All components are cemented to the spectrometer body. The CCD detector has an integrated Peltier element which must be externally controlled. The heat dissipated from the Peltier element passes through a

copper block to the cooling body with fan. An operating and cooling electronic made by tec5 is available from Carl Zeiss. One option is to equip the spectrometer only with the preamplifier for the tec5 operating electronic. A mounting of the preamplifier is recommended because of the light sealing of the module at the detector.

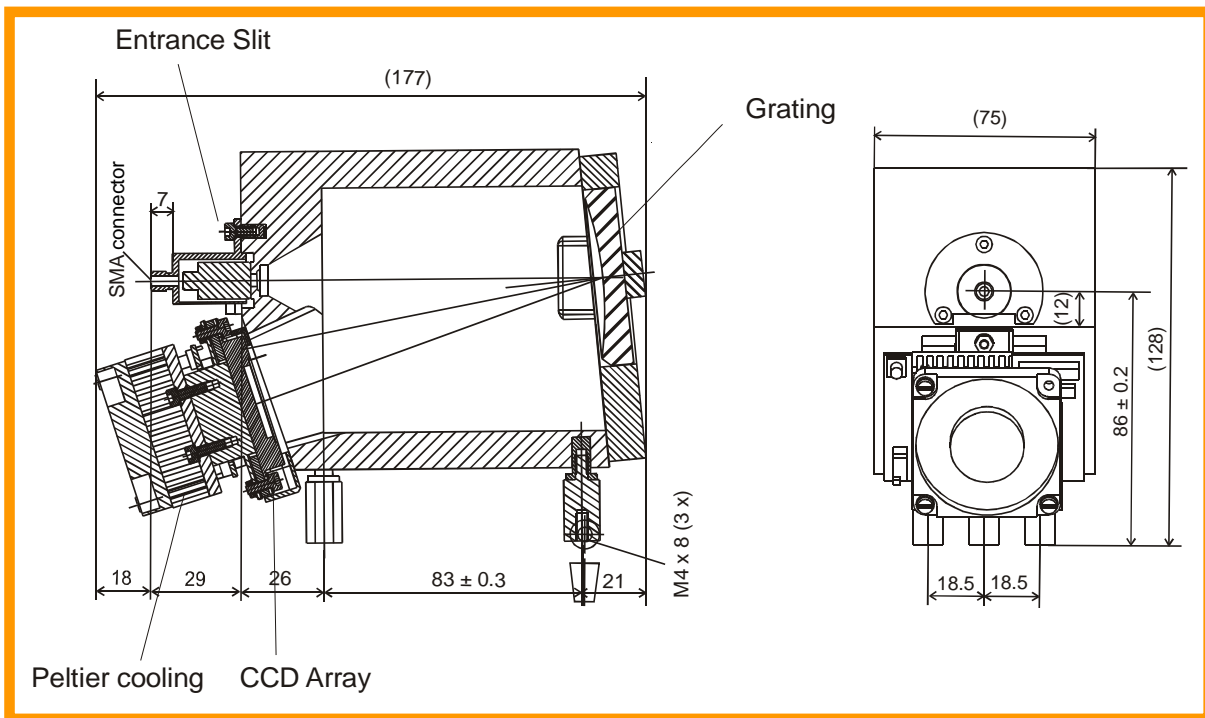

Benefits

- Very high sensitivity
- Detection of low light levels
- Use for diverse measuring tasks; e.g fluorescence measurement
- Robust and thermally stable

Specifications

Optical Entrance:	Cross section converter:
CSC version:	diameter: 0.5 NA = 0.22 mounted in SMA-coupling, dismountable
Entrance slit:	70 μm x 1400 μm (optical entrance)
Grating:	Flat-field correction 248 l/mm (center) blazed for approx. 250 nm
Spectral range:	200 nm ... 980 nm (specifications for the range 220 nm... 980 nm depending on the position and type of CCD array are used)
Wavelength accuracy absolute:	< 0.5 nm
Reproducibility:	< 0,1nm
Temperature - induced drift:	< 0.01 nm/K
Spectral distance of pixel:	$\Delta\lambda_{\text{Pixel}} \approx 0,8 \text{ nm}$
Resolution (FWHM: Full width half maximum):	$\Delta\lambda \leq 3 \text{ nm}$ (UV-Version) $\Delta\lambda = 3...4 \text{ nm}$ (UV-NIR Version)
Straylight:	0.1% measured at 340 nm with Deuterium lamp (transmission of NaNO ₂ solution, 50g/l, 1cm)
Dimensions:	177 x 178x 75 mm ³ (see drawing)
Options:	MCS CCD UV-NIR 200-980 MCS CCD UV 200-600

CCD Array

Producer: Hamamatsu
 Type: S 7031-906
 S 7031-1006

 Number of pixels: 532 x 64 oder 1044 x 64
 Dimensions of pixels: 24 x 24 μm^2
 Maximum clock – rate: 2 MHz
 Blocking filter for the second order is directly coated on the CCD array.

Interface

PinNo.	Symbols	Function	Remarks	PinNo.	Symbols	Function	Remarks
1	RD	Reset Drain		13	TG	Transfer Gate	same pulse as 1'2V
2	os	Output Transistor Source		14	P2V	CCD Vertical Register Clock-2	
3	OD	Output Transistor Drain		15	P1V	CCD Vertical Register Clock-1	
4	OG	Output Gate		16	Th1	Thermistor	
5	SG	Summing Gate	same pulse as P211	17	Th2	Thermistor	
6	-			18	P-	Peltier-	
7	-			19	P'	Peltier'	
8	P2H	CCD Horizontal Register Clock-2		20	SS	Substrate(GND)	
9	PIH	CCD Horizontal Register Clock-1		21	ISV	Test Point (Vertical Input Source)	connect to RD
10	IG2H	Test Point(Horizontal Input Gate-2)	conn ect. to OV	22	IG2V	Test Point (Vertical Input Gate-2)	connect to OV
11	1GIH	Test Point(lhorizontal Input Gate-1)	connect to OV	23	IG1V	Test Point (Vertical Input Gate-1)	connect to OV
12	ISH	Test Point(1-horizontal Input Source)	connect to RD	24	RG	Reset Gate	

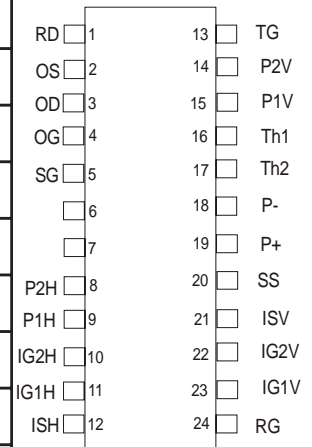

System data

Realised with: 16-Bit-AD-conversion,
 tec 5 operating electronic,
 integration time 10 ms,
 100 KHz and 50 cycles averaging
 ≥ 14 bit*
 Dynamic range:
 * = \log_2 (FS/sdd), FS = full scale = max. signal, sdd= standard deviation(rms) of dark signal, 100 single readouts at 10 ms. The dynamic range can be enlarged by averaging.
 Noise: 2...4 count standard deviation

Carl Zeiss Jena GmbH
 Spektralsensorik

D-07740 Jena
 Phone: ++49 3641 64 2838
 Fax: ++49 3641 64 2485
 E-Mail: info.spektralsensorik@zeiss.de
 Internet: http:// www.zeiss.de/spectral